

Code	Description
1A	615613 Motor housing assembly
2A	615614 Throttle valve seat
3A	615615 Throttle valve assembly
4	615616 Throttle valve spring

Code	Description
5	615617 Exhaust deflector
6	615618 Air strainer
7	615619 Grease fitting
8	615620 Reverse valve bushing seal

Code	Description
9	615621 Reverse valve
10	615622 Steel ball
11	615623 Spring
12	615624 Reverse valve knob
13	615625 Reverse valve knob screw
14A	615626 Trigger
15	615627 Valve pin
16	615628 End plate gasket
17	615629 Rear rotor bearing retainer
18	615630 Rear rotor bearing
19	615631 Rear end plate
20	615632 Rotor
20A	615633 O-ring
21	615634 Cylinder
22	615635 Rotor blade
23	615636 Cylinder dowel
24	615637 Front end plate
25	615638 Front rotor bearing
26	615639 Hammer frame rear washer
27	615640 Hammer case gasket
28	615641 Hammer frame
29	615642 Hammer
30	615643 Hammer pin
31	615644 Standard anvil
32	615645 Hammer case bushing
33	615646 Hammer case
34	615647 Hammer case cap screw
35	615648 Retainer O-ring
36	615649 Socket retainer
37	615650 Reversible valve bushing
38	615651 Tune- up kit (incl.10, 12, 16, 22x6, 35, 36)

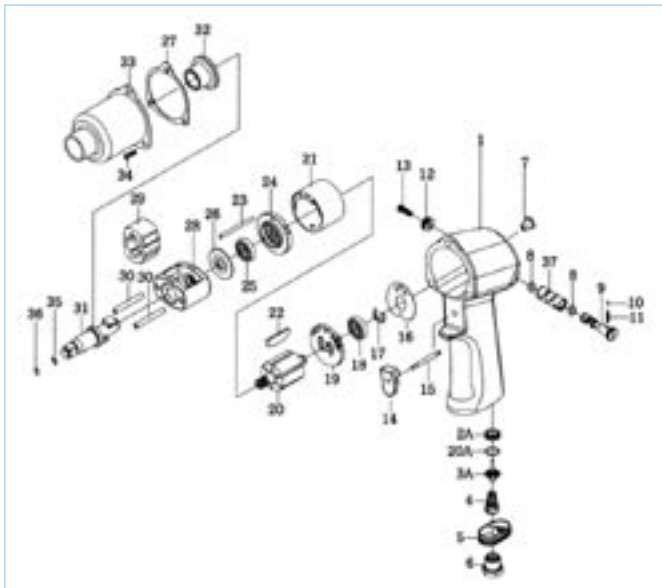

3/8" pneumatic reversible hammer

Article: 1541

Code: 615320



WARNING :

- * always read the instruction before using power tools
- * always wear safety goggles
- * wear hearing protection
- * Avoid prolonged exposure to vibration



Pneumatic reversible hammer 1541 apply to PREN 792 -6.

Vibration level per ISO 8662-7

Noise level according to ISO 3746:1995 (E)

Maximum air pressure: 6.2 BAR (90 PSI)

Square Drive	S.T.D Bolt Size		Free Speed	Max. Torque		Overall Length		Air Inlet	Air Hose	Avg. AirConsumption		Net Weight		Sound Pressure	Vibration
	inch	mm		ft-lb	N.M	inch	mm			PT	I.D	cfm	l/min		
3/8	7/16	M10	10000	200	271	5 1/2	139	1/4	3/8	2.5	70.8	2.97	1.35	94	2,2

OPERATING INSTRUCTION

1. Warning

1.1 Air pressure :

The air pressure must be restricted at or less than the maximum pressure of 90 psi (6.2 bar), do not exceed it.

1.2 Air line :

Use an air hose between the compressor and the tool. The corresponding hose internal diameter is recommended in the attached table in the data sheet. Compressed air is cooled and its water content separated as soon as the air leaves the compressor. However some of the water is condensed in the piping, and can enter the tool mechanism and cause damage. An air filter and an oiler should be installed between the compressor and the tool. Use a recommended compressor in the data sheet or larger for each tool.

1.3 Air hose

Clean the hose with a blast of compressed air before connecting the hose to air tool. This will prevent both moisture and dust within the hose from entering the tool and causing possible rust or malfunction. To compensate for unusually long hose (over 25ft) the line pressure should be increased accordingly.

1.4 Sockets :

The tool is used fastening or loosening of threaded fasteners. The sockets must be of the impact type with suitable square drive dimension. Do not use any other type of socket.

1.5 Approved eye protection, mask, hearing protection and gloves shall be worn when operate this tools.

1.6 The working place shall be ventilated.

1.7 Release the on-off device in case of air supply failure.

1.8 Ensure that the power tool is firmly attached when using a suspension device.

1.9 Release the start and stop switch in case of a failure of energy supply.

1.10 Use only a lubricant recommended by the manufacturer.

2. Operation method

2.1 On-off switch

The on-off switch is on the inside or outside of the grip. It is a " hold-to-run" type. This tool stops rotation in a few seconds after releasing the lever. For the sake of safety, please ensure it has completely stopped before touching.

2.2 Torque adjuster :

You can adjust the torque by rotation the knob. Torque is indicated by numbers. Lower number indicates lower output torque setting and vise versa.

2.3 Rotating direction :

Ensure the direction of rotation is correct before operation. The "F" indicates forward and the "R" indicate reverse. Forward is defined as clockwise viewed from the operators position.

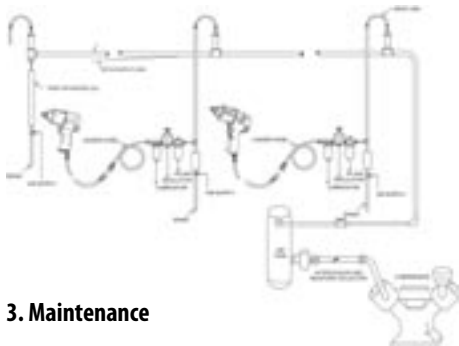

3. Maintenance

3.1 Lubrication :

Before connecting the hose, apply 4 to 5 drops of # 60 spindle oil at the inlet. Use of a thicker oil can lead to reduced performance of malfunction. Also oil after every 3 to 4 hours of operation.

3.2 Storage :

Avoid storing the tool in a location subject to high humidity. If the tool is left as it is used, the residual moisture inside the tool can cause rust. Before storing and after operation, oil the tool at the air inlet with spindle oil and run it for a short time.

3.3 Ordering service part .

For further operational and handling information or for replacement of parts and components contact the outlet from where you purchased the tool or the service division of your company.

WARNING

1. The tool should not be used in potentially explosive atmospheres
2. Disconnect the air hose before changing or adjusting any sockets.
3. Before using the tool, please ensure that all connections are secure. Loose air hoses may become disconnected and may be caught in the revolving spindle.
4. Prevent loose clothes, long hair etc. from coming into contact with the revolving spindle, as this could cause injury.
5. Excessive high air pressure that exceeds the recommended maximum pressure may cause injuries to the user.
6. Keep your body in well balanced position and always wear gloves to reduce the risk of becoming trapped due to torque between handle and work piece.
7. Prolonged exposure to vibration can cause injury.
8. Ensure that you are aware of the direction of rotation before starting the tool. Failure to do so may cause injury.
9. Slip/trip/fall is a major reason of serious injury. Beware of excess hose left on the workplace floor.
10. Wearing eye/ face protector reduce the danger

to the operator from flying objects caused by socket failure or other reasons.

11. Wearing correct breathing protection could avoid inhaling dust or debris from work process that can be harmful to your health.
12. Never operate the tool away from the workplace. It may cause the accessories to be detached from the tool and cause injury to someone in the vicinity.
13. High sound level can cause permanent hearing loss. Use hearing protection while operating the tool.
14. The ratchet wrench may kickback and cause injury if the nut is too tight. In this situation use manual operation to loosen the nut before continuing to use the power tool.
15. Unexpected tool movement due to reaction forces or breakage of sockets or reaction bar may cause injuries.
16. There is a risk of being injured specially when working in confined areas if hands are not kept away from the reaction bar. Keep hands away from the socket.
17. In case of socket failure, there may be danger to people from fragments being flying from the impact wrench.
18. Be aware of whipping compressed air hose.
19. The power tool is not insulated and must be kept away from electric power source.

Warranty:

Unior d.d. offers one year free charge service warranty to the products supplied by Unior d.d. and authorized dealers.

All products are warranted under following conditions :

- one year from the date of purchase for tools with Unior brand name
- the free charge service only applies to defects in material and workmanship. The guarantee becomes invalid if the tool has been improperly used or has been repaired using non genuine spare parts and/or has been modified or repaired by someone other than UNIOR d.d. authorized service representatives

UNIOR d.d.

Kovaška cesta 10, 3214 Zreče, SLOVENIA

EU Declaration of Conformity

Hereby, we declare under our sole responsibility that the following product **Article 1541 Pneumatic reversible hammer**, the serial number and year of production marked on the product, are in conformity with essential safety and health requirements EU Machinery directive 98/37/ES following provisions of the harmonized standards mentioned below: EN 792-6:2000 - Hand-held non-electric power tools - Safety requirements - Part 6: Assembly power tools for threaded fasteners EN ISO 8662-7:2000 - Hand-held portable power tools - Measurement of vibrations at the handle EN ISO 3746: 1997 - Acoustic - Determination of sound power levels of noise sources using sound pressure

Zreče, December 2004

Gorazd Korošec, President



Name and signature of the authorized person